

**THE VIETNAMESE EUCHARISTIC YOUTH SOCIETY  
IN THE USA**

**STUDENT WORKBOOK  
SEARCH DIVISION  
LEVEL II**

**Saint Name:**\_\_\_\_\_

**Name:**\_\_\_\_\_

**Team:**\_\_\_\_\_

**Division Youth-Leader:**\_\_\_\_\_

**Chapter:**\_\_\_\_\_

**Region:**\_\_\_\_\_

# Asking For God's Help – Xin Được Sáng Suốt

## Lời Chúa/Word of God

<sup>27</sup>

(Mt 9:27)

<sup>27</sup> As Jesus went on from there, two blind men followed Him, crying out, "Have mercy on us, Son of David!"

## Kiến Thức Liên Quan/Fact Finding

2008 - kê cho trung bình các em nói ng 10 8 45 phút 8 Hoa ngày  
 các em làm không 75 15 phút trong ích cho thân các em.

- Sáng

lai thân.

- Không

tình

According to the Kaiser Family Foundation survey in the year 2008-2009 of 2002 adolescents with the average ages from 8 to 18 in the US. The survey shows on average teenagers spent 10 hours and 45 minutes a day watching TV, playing games, visiting on social media webpages, (Facebook, Twitter) and talk on the phone, etc. On the average, they've spent 75 hours and 15 minutes weekly on the activities that are not very useful in for their lives.

### Logic:

- Have the wisdom to choose useful activities on the daily basis = become useful people + establish relationship with God and family + focus on school + healthy activity (sports, school organization, TNTT)
- Not having the wisdom and choose the useless activities on the daily basis = waste of your precious time + hurt yourself + lost your love from others.



## Áp Dụng Cuộc Sống/Life Application

| <u>Nhận ra những việc làm có lợi ích hoặc việc làm không có lợi ích:</u><br><u>Recognize activities that are useful or useless:</u> | <u>Các em gì ả thích tại sao những việc làm này tốt hay xấu:</u><br><u>Explain why these activities are good or bad?</u> |
|---|--|
| <i>Tham d thánh l và sinh ho t TNTT / Attending mass and attending sinh hoạt TNTT</i>   |  |
| <i>Giúp i nghèo / Help the poor</i>   |  |
| <i>T p th d trái cây và rau c i / Exercise, eat fruits &amp; vegetables</i>   |  |
| <i>Ch xem TV và không làm vi c gì khác / Watching TV only and do nothing else.</i>  |  |

## Ôn Bài Lại/Summary

Các e

ân. Chúng ta

chúng

siêng tham  
và các huynh

We need the wisdom to pick out what are good for us, which will give the best result in the future. We also need the wisdom to recognize and to avoid the activities that are are not useful. We need to have faith in God, receive Jesus spiritually, attende mass and pray often to seek for the wisdom to listen to God's words and learning from our teachers, our parents and our youth leaders

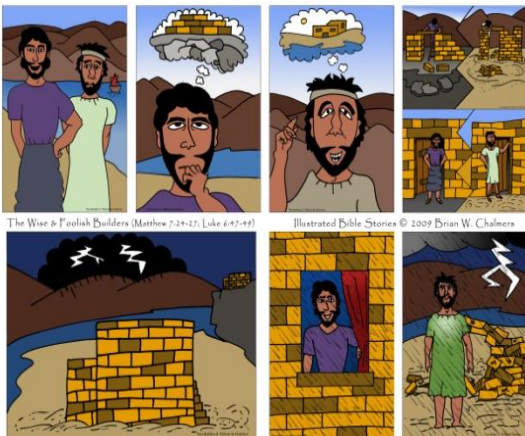

## Lời Nguyện/ Prayer

Chúa ban soi sáng  
tính và tránh ng vi

Oh Lord, please give me the wisdom to pick activities that will help me grow stronger in faith, also please give me the wisdom to recognize my bad habits and avoid any activities that would offend you.

## Bài Làm/Homework

1. *T i sao em ph i có nh ng ch n l a sáng su t?* Why should we pick your choices wisely?

---

---

---

2. *Khi chúng ta ch n l a nh ng vi c làm vô b thì h u qu s ra sao?* What are the consequences of the choices we make?

# Our Responsibilities – Xin Được Biết Chu Toàn Bản Phần

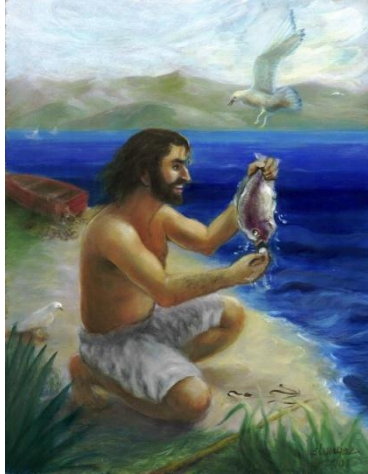

## Lời Chúa/Words of God

<sup>24</sup> -phác-na- <sup>25</sup> Ông  
- -  
  
<sup>26</sup> Ông Phê- <sup>27</sup>  
- -

anh."(Mt 17: 24-27)

<sup>24</sup> After Jesus and his disciples arrived in Capernaum, the collectors of the two-drachma temple tax came to Peter and asked, “Doesn’t your teacher pay the temple tax?”<sup>25</sup> “Yes, he does,” he replied. When Peter came into the house, Jesus was the first to speak. “What do you think, Simon?” he asked. “From whom do the kings of the earth collect duty and taxes—from their own children or from others?”<sup>26</sup> “From others,” Peter answered. “Then the children are exempt,” Jesus said to him. <sup>27</sup> “But so that we may not cause offense, go to the lake and throw out your line. Take the first fish you catch; open its mouth and you will find a four-drachma coin. Take it and give it to them for my tax and yours.”

## Kiến Thức Liên Quan/Fact Finding

### CATECHISM OF THE CATHOLIC CHURCH

**2247** "Honor your father and your mother" (*Deut* 5:16; *Mk* 7:10).

**2248** According to the fourth commandment, God has willed that, after him, we should honor our parents and those whom he has vested with authority for our good.

**2249** The conjugal community is established upon the covenant and consent of the spouses. Marriage and family are ordered to the good of the spouses, to the procreation and the education of children.

**2250** "The well-being of the individual person and of both human and Christian society is closely bound up with the healthy state of conjugal and family life" (*GS* 47 § 1).

**2251** Children owe their parents respect, gratitude, just obedience, and assistance. Filial respect fosters harmony in all of family life.

**2252** Parents have the first responsibility for the education of their children in the faith, prayer, and all the virtues. They have the duty to provide as far as possible for the physical and spiritual needs of their children.

**2253** Parents should respect and encourage their children's vocations. They should remember and teach that the first calling of the Christian is to follow Jesus.

**2254** Public authority is obliged to respect the fundamental rights of the human person and the conditions for the exercise of his freedom.

**2255** It is the duty of citizens to work with civil authority for building up society in a spirit of truth, justice, solidarity, and freedom.

**2256** Citizens are obliged in conscience not to follow the directives of civil authorities when they are contrary to the demands of the moral order. "We must obey God rather than men" (*Acts 5:29*).

**2257** Every society's judgments and conduct reflect a vision of man and his destiny. Without the light the Gospel sheds on God and man, societies easily become totalitarian.

### Áp Dụng Cuộc Sống/Life Application

Mark is the manager at Sears. His job is to oversee a group of employees and make sure that things are running smoothly. His wife, Amanda is a teacher at the local high school. Her job is to educate the students and prepare them to become productive citizens. Steven is a seventh grade at the local junior high school.



1. What are Steven's responsibilities?

---

2. Do Steven's parents have to pay tax for the income they make from their jobs? Why?

---

---

---

### Ôn Bài Lại/Summary

Everyone has responsibilities. If we neglect our responsibilities, we affect not only ourselves, but also others around us.

### Lời Nguyện/Prayer

*Chúa. Xin Chúa cho chúng con biết hy sinh và là*

Lord, please teach us to be mindful in participating in the building of the Church of God. Please teach us know how to sacrifice and fulfill the responsibilities as Christians.

### Bài Làm/Homework



1) What are the responsibilities of TNTT member?

---

---

---

---

2) What are the children's responsibilities within the family?

---

---

---

3) *Chúa Giê* How did Jesus fulfill his responsibilities?

---

---

---

# Listening – Xin Biết Lắng Nghe

## Lời Chúa/ Words of God



*anh.*

*-pha-*

36)

Again he left the district of Tyre and went by way of Sidon to the Sea of Galilee, into the district of the Decapolis. And people brought to him a deaf man who had a speech impediment and begged him to lay his hand on him. He took him off by himself away from the crowd. He put his finger into the man's ears and, spitting, touched his tongue; then he looked up to heaven and groaned, and said to him, "Ephphatha!" (means "Be opened!"). And (immediately) the man's ears were opened, his speech impediment was removed, and he spoke plainly. He ordered them not to tell anyone. But the more he ordered them not to, the more they proclaimed it. They were exceedingly astonished and they said, "He has done all things well. He makes the deaf hear and mute speak." (Mk 7:31 – 36)

## Kiến Thức Liên Quan/Fact Finding

A Brief Summary of Estimates for the Size of the Deaf Population in the USA Based on Available Federal Data and Published Research: (<http://research.gallaudet.edu/Demographics/deaf-US.php>)

- About 2 to 4 of every 1,000 people in the United States are "functionally deaf," though more than half became deaf relatively late in life; fewer than 1 out of every 1,000 people in the United States became deaf before 18 years of age.
- However, if people with a severe hearing impairment are included with those who are deaf, then the number is 4 to 10 times higher. That is, anywhere from 9 to 22 out of every 1,000 people have a severe hearing impairment or are deaf. Again, at least half of these people reported their hearing loss after 64 years of age.
- Finally, if everyone who has any kind of "trouble" with





their hearing is included then anywhere from 37 to 140 out of every 1,000 people in the United States have some kind of hearing loss, with a large share being at least 65 years old.

As a Catholic, what do we do after listening the Word of God weekly?

Anyone who listens to the Word of God can and must speak and transmit it to others, to those who have never heard it, or who have forgotten it and buried under the thorny troubles and deceptions of the world (cf. Mt 13: 22).

Are we afraid? Why is that?

### Áp Dụng Cuộc Sống/Life Application

| <i>y Cô/Huynh</i>                        | <i>không nghe</i>   |  |
|--|---|--|
| Parents/Teachers/Youth-Leaders tell you: | What do you think the results for not listening would be? | What do you think the results of listening and understanding |
| <i>người</i><br>Be respectful to all     | 1<br>2<br>3   | 1<br>2<br>3  |
| Be patient                               | 1<br>2<br>3   | 1<br>2<br>3  |
| Go to school regularly                   | 1<br>2<br>3   | 1<br>2<br>3  |
| Don't hang out with bad friends          | 1<br>2<br>3   | 1<br>2<br>3  |

### Ôn Bài Lại /Summary

Jesus healed the deaf-mute person. The man was able to hear and speak because of his faith in God . For us, we have ears and eyes. We hear and see all creatures God made. Are we really listening to God's talking through priests, parents, teachers, youth leaders and friends, etc.?

### Lời Nguyện/Prayer

*gì con không*

Oh Lord, please grant us the ability to truly listen, we know how to hear, but do not know how to listen. Please help us to have the patience to listen to things we may not want to hear, because those come from the people who care for us and want to help us become a better person.

**Bài Làm/Homework**

1.

*u*

For one whole day, do not speak unless spoken to or when you are asked a question. After that day, write down what you learned.

---

---

2.

? Do

you think you would have heard the things you heard if you actually spoke that day?

---

---

3.

Did you hear anything that was

surprising to you?

---

---

## Keeping Clean – Xin Được Trong Sạch



### Lời Chúa - Words of God

<sup>12</sup> While He was in one of the cities, behold, there *was* a man <sup>[a]</sup>covered with leprosy; and when he saw Jesus, he fell on his face and implored Him, saying, “Lord, if You are willing, You can make me clean.” <sup>13</sup> And He stretched out His hand and touched him, saying, “I am willing; be cleansed.” And immediately the leprosy left him. <sup>14</sup> And He ordered him to tell no one, “But go and show yourself to the priest and make an offering for your cleansing, just as Moses commanded, as a testimony to them.” (Lk 5:12 –14)

### Kiến Thức Liên Quan/Fact Finding

In Jesus' time people who were *physically* unclean or who had a disease were considered to be *spiritually* unclean and could not participate in prayers or make sacrifices in the temple.

The people in Palestine were afraid of lepers because they could infect healthy people with their disease, and they despised the lepers as people who must have committed terrible secret sins.

Since leprosy shows in the skin, lepers could not hide their illness from the community, so they were shunned and forced to live apart, because other people were afraid they could catch their disease from them.

Though leprosy is not fatal, it can affect the voice and vision, as well as the skin, nose, toes, and fingers, and the leper's physical condition continued to deteriorate during his or her lifetime.

Because lepers could not participate in worship, most people believed that the disease was a punishment for earlier sins - not being able to worship God was the worst punishment people could imagine - so people thought the lepers must have done something horrible to be punished so severely for their whole lifetimes.

That Jesus could cure a disease that no one else could even stop in its course shows that he was a true worker of miracles. That Jesus cured so many people who were prevented from praying and worshipping shows that his mission on earth was to reconcile people to God.

<http://www.sundayschoollessons.com/pen19les.htm>

## **Áp Dụng Cuộc Sống - Life Application**

# Thanksgiving – Xin Được Biết Tạ Ơn

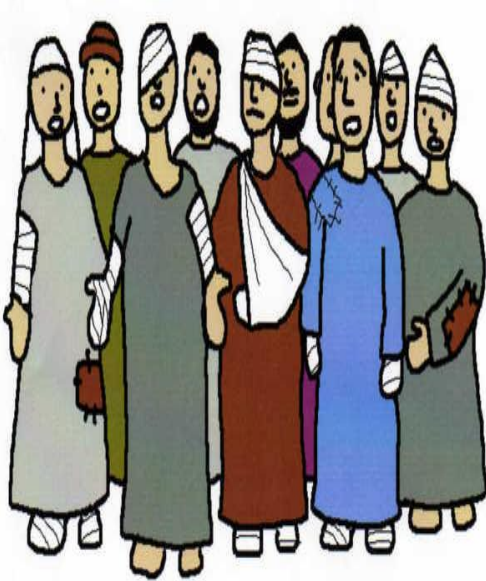

## Lời Chúa/Word of God

11 -ru-sa- -  
 -ma-ri và Ga-li-lê.<sup>12</sup>

Giê- 13  
 Giê- 14

15 -  
 -ma-ri.<sup>17</sup> -

18 19  
 (Lk

17:11-19)

<sup>11</sup> As he continued his journey to Jerusalem, he traveled through Samaria and Galilee. <sup>12</sup> As he was entering a village, ten lepers met (him). They stood at a distance from him <sup>13</sup> and raised their voice, saying, "Jesus, Master! Have pity on us!"<sup>14</sup> And when he saw them, he said, "Go show yourselves to the priests." As they were going they were cleansed. <sup>15</sup> And one of them, realizing he had been healed, returned, glorifying God in a loud voice;<sup>16</sup> and he fell at the feet of Jesus and thanked him. He was a Samaritan. <sup>17</sup> Jesus said in reply, "Ten were cleansed, were they not? Where are the other nine?" <sup>18</sup> Has none but this foreigner returned to give thanks to God?" <sup>19</sup> Then he said to him, "Stand up and go; your faith has saved you." (Lk 17:11-19)

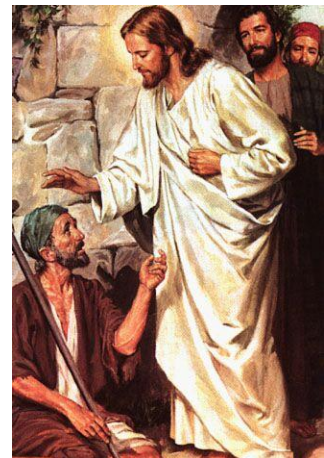

## Kiến Thức Liên Quan/ Fact Finding

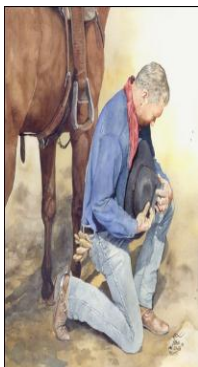

<http://www.missionarlinton.org/d/LOC09-40-TenLepers.pdf>

**The sacrifice that honors me is a thankful heart. Obey me, and I, your God, will show my power to save. Psalm 50:23**

Being thankful is very important to God. There are many verses in the Bible that tell us to be thankful. When we have a thankful heart, we are showing God that we recognize where our blessings come from. It also reminds us to keep our focus on God and to give Him the glory for everything.

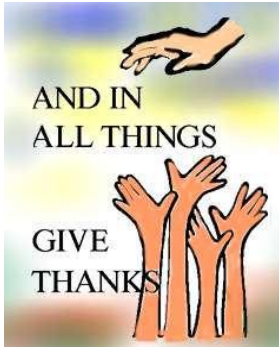

The most important thing to be thankful for is our salvation. Remember—we cannot save ourselves. Salvation is a free gift from God that we can receive because of what Jesus did for us on the cross. He died so that we might live. We can be forgiven of our sins and have eternal life.

Have you received this gift? If not, you can invite Christ into your heart today. And if you have received Jesus, remember to be thankful for all of his blessings.

### Áp Dụng Cuộc Sống/Life Application

All ten of the men asked Jesus to heal them. But only one of them made the extra effort to return to Jesus and thank Him. He was the only one who received a right relationship with God. The others were healed physically (their bodies), but the Samaritan man was also healed spiritually (his soul).

Some people only think about their physical life—what they will eat and drink, the things they have and the clothes they wear. But Jesus taught that we must think more about the spiritual things, like having a relationship with God. That is the only thing that will last forever. So when you get tempted to want more and more things, remember to turn to God and thank Him for everything He has done for you. Then spend time getting to know Him better. That is the way to be blessed.

1)

Waking up in the morning, Thanks God for a good, safe night sleep.

2)

When you consume food, give Thanks to those people who prepared food for you.

3)

When your friends lend you books, notes, pens, give Thanks to them.

4) *Em hãy nói*

Give Thanks to your parents for giving you shelter and food on the table.

1)

Everytime you desire to receive Jesus spiritually, say the Spiritual Communion Prayer to receive him spiritually and thanks him for giving himself to save us



6)

Every night, remember to give Thanks to God because he gave you a beautiful world that you live in. He also gave you a family, friends to help and support you in your life/

### Ôn Bài Lại/Summary

- Being thankful for God's help
- Obeying God without questioning
- Jesus is a healer

### Lời Nguyện/Prayer

We have so much to be thankful for not matter if we are disabled or whatever our circumstances may be. God is truly in control and we need to be thankful for Him. As you pray ask the Lord to help you to be humble as He has called us to be humble..

### Bài Làm /Homework

<http://www.ccstpete.com/cm/devotionals/DEVNT252.pdf>

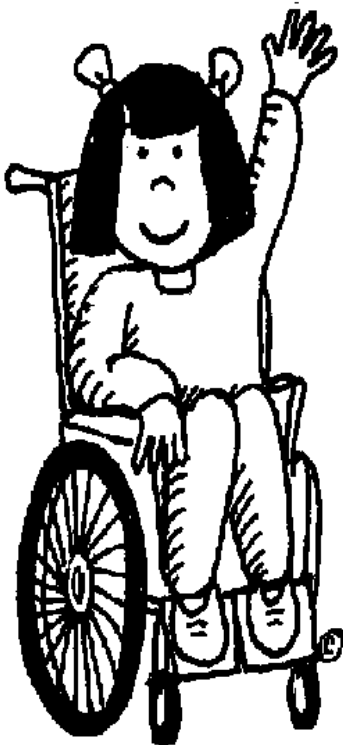

Read the story and prepare the answers to share with class next week.

Tommy couldn't understand why he was going through this terrible sickness. "I am a prisoner, trapped in my own home!" He thought. Tommy had a rare disease that required him to stay inside of his house. If he were to go outside he would come into contact with many invisible germs that could get inside his body and make him more sick or even cause him to die. It was very difficult for Tommy to be inside of his house most of the day.

One afternoon, Tommy was standing next to the window and noticed a girl wheeling her wheelchair on the sidewalk. The child was probably close to Tommy's age, which was ten years old. The girl did not have any legs and seemed to struggle to push her wheelchair down the sidewalk. But the entire time she had a big smile on her face and when she saw Tommy standing by the window she waved to him. Tommy waved back. He couldn't understand why she was smiling so big or why she waved to him. The girl steered her wheelchair closer to the window.

She reached into a backpack she had connected to the chair and pulled out a writing tablet and a pen. She began writing questions

on the pad. “How come I never see you outside? How old are you? Can you come outside and play?” After reading the messages, Tommy started to get depressed because he knew there was no way for him to go outside. Tommy retrieved a tablet and responded back to the girl outside.

“I am 10 years old and I can’t come outside because I have a disease.” The little girl responded back with “That’s OK. I have a disease too. But someday I will have a new body without any diseases or any problems at all.” Tommy thought to himself, “What is this girl so happy about and what does she mean about getting a new body?”

From that point on, every day after school Angela (the girl in the wheelchair) would stop by to talk to Tommy. She learned about Tommy’s rare disease and began to communicate with him by writing notes on a tablet. Angela was always joyful, friendly, and she always had a smile on her face. Many times, Angela would tell Tommy about Jesus and how He changed her life. She told Tommy about having a new life and that someday when she died she would get a brand new body. Tommy accepted Christ as his savior one day while visiting with Angela.



God was using Angela despite her illness. Angela bought Tommy a Bible on his birthday. She gave him a guide he could use to find Bible verses and learn more about Jesus. Everyday at around 3:25 p.m. Tommy would walk over to the window to wait for his friend Angela. One day, Tommy went over by the window

and waited for Angela. He waited and waited, and there was no Angela. “Angela has not missed a visit for almost two years!” “Were could she be?” Another day went by and no Angela. Four days went by before Tommy heard anything about Angela. Finally on the last day, Tommy received a message from Angela’s Father. Angela had a severe infection and was hospitalized. Angela died while she was in the hospital. Tommy was very upset.

Tommy started to feel depressed again. As Tommy opened up his Bible that evening, he noticed a bookmark that Angela had given to him. On the bookmark was a Bible Verse Angela wrote for Tommy; “In everything give thanks; for this is the will of God in Christ Jesus for you.” 1 Thessalonians 5:18. Instead of looking down, Tommy looked up. He was thankful for meeting Angela. He was thankful that Angela introduced him to Jesus Christ. Tommy knew that his illness would bring God glory just like it did with Angela.

- How did the Lord use Angela even though she had an illness?
  
  
  
  
  
  
  
  
  
  
- What did Tommy learn about thankfulness? What have you learned?

- Would it be difficult for you to give praise or thanks to God even if you were to have a disability or disease?

- When we receive God's gift of eternal life we are "saved" from the penalty of death, separation from God. We receive a new life by faith

- Can you guess why the girl is so happy?



**Eucharist 1-Search Division-Student**

at Mass so that Catholics would become more familiar with the text of the Bible. As a result we now have a three-year cycle of readings built around readings from the three synoptic Gospels—Matthew, Mark, and Luke.

- **Meaning:** It is the time for us to contemplate about the teaching of Jesus while he was living on earth.
- **Color:** green



#### 4. Lent Season

- **Time:** It begins on [Ash Wednesday](#) and, if the penitential days of [Good Friday](#) and [Holy Saturday](#) are included, lasts for forty days. The week before Easter is called the Holy Week.
- **Meaning:** Preparation for Easter. It is time for Christians to look back into their lives examining their sins and go to confession to receive the Sacrament of Reconciliation.
- **Color:** violet.

#### 5. Easter Season

- **Time:** varies from year to year, according to a lunar-calendar dating system. In the Roman Rite, the Easter season extends from the [Easter Vigil](#) through [Pentecost](#) Sunday.
- **Meaning:** Jesus Christ is Risen! Easter celebrates the resurrection of Jesus, the central feast of Christianity
- **Color:** white

### Summary

In the liturgical year, the Church unfolds the entire mystery of Christ. This mystery is so complex and rich in meaning that no one single prayer or liturgical celebration can ever express it adequately.

The liturgical year helps us to “walk around” the paschal mystery. During the course of a year, we view it from different angles, in different lights. Within the cycle of a year, the Church unfolds the whole mystery of Christ, from his incarnation and birth until his ascension, the day of Pentecost, and the expectation of his return in glory.

As we celebrate the mystery of Christ, we are not merely recalling the past events. When we celebrate in memory of Jesus, our liturgical remembering (anamnesis) makes the mystery present.

The liturgical year, with its various feasts and seasons, helps us to keep our hearts open *each day* to the voice of God in our lives and in our world.

<http://www.holyfamilyparish.org/youth/documents/LP5IgniteTheChurchYear2010-11.pdf>

## Prayer

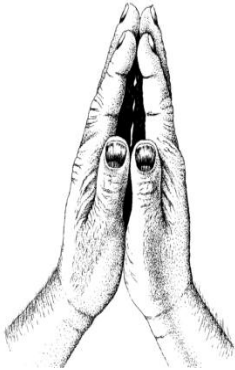

*God of all seasons,  
Help me to remember the sun when it is raining.  
Help me to remember the rain when it is shining.  
Teach me to respect the unpopular students when I am popular.  
Teach me to respect the popular students when I am unpopular.  
When I win a game, help me to remember the times I lost.  
When I lose a game, help me to remember the times I won.  
When I am with my friends, remind me of times when I am alone.  
When I am alone, remind me of the times when I am with friends.  
Help me to understand that there is a balance to life,  
Just as in the seasons of earth.*

## Practicing our Faith

Attend mass or go to Adoration whenever possible because in mass it is when we can truly be with Jesus and to strengthen our relationship with Him.

Strive to help others as much as possible when you can.

## Faith alive at home

Say the Rosary with your family each night to contemplate on the life of Jesus

### Discussion

1. What are the seasons in the Liturgical years?
2. What are the meanings of Advent and Lent seasons?
3. What are the masses celebrated in Christmas and Easter season?

### True or False

- \_\_\_ there are 4 seasons in the Liturgical year?
- \_\_\_ Ash Wednesday is celebrated in Lent season?
- \_\_\_ Ordinary Time season is before Christmas season?

# Readings in Mass

## Reading the Bible

*John 1:1* In the beginning was the Word, and the Word was with God, and the Word was God.

## Studying Our Faith

### Sunday Mass

1. The **first reading** comes from the Old Testament (except for during Easter). The reading and the responsorial psalm are chosen so that they relate to the gospel reading.
  2. The **second reading** is from the New Testament, usually from one of the 13 Pauline epistles. They follow a continual system like the Gospels. The Letters of St. Paul and St. James are read during Ordinary time, while those of John and Peter are read during Christmas and Easter. They do not seem to fit in well with the gospel since they use their own system.
  3. For the **Gospel readings**, each year is dedicated to one of the synoptic gospels. The next year continues on in the Gospel reading cycle. The new lectionary year begins on the first Sunday of Advent.
    - Year A for Matthew
    - Year B for Mark
    - Year C for Luke
    - The gospel of John is read each year, primarily during Christmas, Lent and Easter.
- During Advent, Christmas, Lent, Easter and solemnities, all three readings are chosen to reflect the liturgical season.
  - Every day during Easter season, the first reading is taken from the Acts of the Apostles. The exact same readings are used each year.
  - Towards the end of the year, the readings come from the books of Revelation and Daniel, which fit well with the apocalyptic sermons from Luke.

### Daily Readings

1. The first reading can be taken from either Testament.
2. During Ordinary time, all four gospels are read using a semi-continual system. Mark weeks 1-9; Matthew 10-12; and Luke 22-34.

The New Testament readings give the substance of almost all the letters, but the Old Testament readings only show the important parts of each book. Almost all of the books are used except some prophets and the Song of Songs.

## Summary

When in celebrating the Liturgy of the Words, the church proclaims God's words in the Old and New Testament. Christ himself is the center and fullness of the whole of Scripture. Thus, the Scripture is the living water for those who seek life and salvation.

*Scripture is inspired by God and profitable for teaching, for reproof, for correction, for training in righteousness;*

*2 Timothy 3:16*



Each Sunday mass has three readings: the first from the Old Testament, the second from an Apostle (that is, either from a Letter or from the Book of Revelation, depending on the season), and the third from the gospels.

This arrangement brings out the unity of the Old and New Testaments and of the history of salvation, in which Christ is the central figure, commemorated in His paschal mystery.

## Prayer

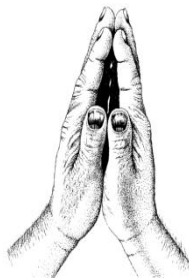

Jesus, thank you for Your gift of the Holy Bible.  
You inspired the prophets and the apostles,  
Guiding them to eternalize the Sacred Word.  
Always maintain our faith in the Holy Word,  
Continue to guide us through its Books,  
Granting us the required insight and wisdom  
To thoroughly digest Your many mysteries.  
We ask this through Christ our Lord. Amen.

## Practicing Our Faith

- The lectionary is organized in a certain way to help us better understand the Word of God. Look over the readings for the Sunday mass to see if there is any connection or common theme, especially the first reading and gospel.
- Listen to the homily to learn more about the message of Jesus.
- During the week, try to think about Jesus' message and act on it.

## Faith Alive At Home

### Share the answer with your parents

1. When does the new lectionary year begin?
2. We are currently in what lectionary year? What gospel writer does it focus on?
3. How do the readings of the mass relate with each other?

### True or False

1. The new lectionary year begins on New Year's Day.
2. During Sunday mass, the first reading comes from the Old Testament.
3. The daily mass has three readings, just like the Sunday readings.

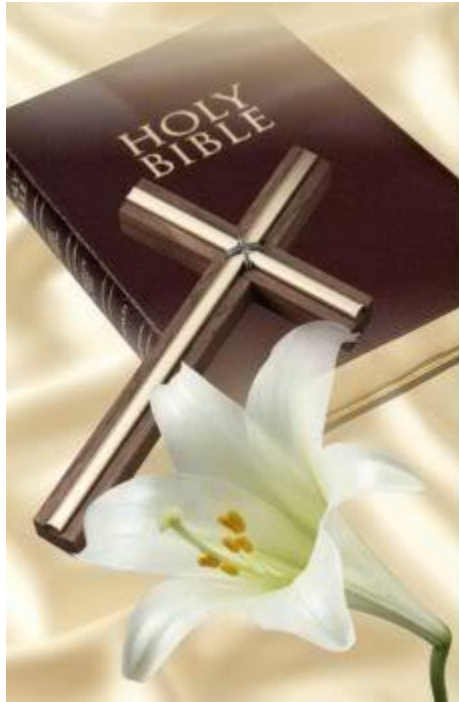

# Holy days of Obligation, Solemnities, Feast, Memorials

## Reading the Bible

*Luke 2:41-42* Now his parents went to Jerusalem every year at the feast of the passover. And when he was twelve years old, they went up to Jerusalem after the custom of the feast

## Studying our Faith

### Solemnity

- Holy days of solemnity/obligation are celebrated to commemorate an event of utmost importance
- Holy days of solemnity normally has Vigil the night before the actual celebration
- Most of the Holy days of Solemnity are also Holy Day of Obligations, so the two terms are interchangeable. See Canon Law section below.

### Feast

- Feast days are days to commemorate and honor an important biblical figures
- Feast days does are not obligatory

### Memorial

- Memorial days are celebrate year round in honor of any figures that is lesser than the previous two categories

### Luật Hội Thánh

#### Canon Law 1246

<http://www.usccb.org/beliefs-and-teachings/what-we-believe/canon-law/complementary-norms/canon-1246.cfm>

On December 13, 1991 the members of the National Conference of Catholic Bishops of the United States of American made the following general decree concerning holy days of obligation for Latin rite Catholics:

In addition to Sunday, the days to be observed **as holy days of obligation in the Latin Rite dioceses of the United States of America**, in conformity with canon 1246, are as follows:

**January 1**, the solemnity of Mary, Mother of God  
**Thursday of the Sixth Week of Easter**, the solemnity of the Ascension

**August 15**, the solemnity of the Assumption of the Blessed Virgin Mary  
**November 1**, the solemnity of All Saints  
**December 8**, the solemnity of the Immaculate Conception  
**December 25**, the solemnity of the Nativity of Our Lord Jesus Christ

Whenever January 1, the solemnity of Mary, Mother of God, or August 15, the solemnity of the Assumption, or November 1, the solemnity of All Saints, falls on a Saturday or on a Monday, the precept to attend Mass is abrogated.

**Canon Law 1247** On Sundays and other holy days of obligation, the faithful are obliged to participate in the Mass.

[http://www.vatican.va/archive/ENG1104/\\_P4N.HTM](http://www.vatican.va/archive/ENG1104/_P4N.HTM)

## Summary

In the Third Commandment, God tells us to “Remember to keep holy the sabbath day.” For the Jews, the sabbath was Saturday; Catholics, however, transferred the sabbath to Sunday, the day of Jesus Christ’s resurrection from the dead. The Church tells us that we have an obligation to fulfill the Third Commandment by refraining from unnecessary work on Sunday and by participating in the Mass, our chief form of worship as Catholics.

### Private Worship Is Not Enough

From the earliest days of the Church, Christians have understood that being a Christian isn’t a private matter. We are called to be Catholics together; while we can and should engage in the private worship of God throughout the week, our primary form of worship is public and communal, which is why Sunday Mass is so important.

Days to remember are:

|   |   |
|---|---|
| The Nativity of our Lord Jesus Christ   | Lễ Giáng Sinh   |
| The Epiphany, the Ascension             | Lễ Hiển Linh, Lễ Chúa Lên Trời                                  |
| The Body and Blood of Christ            | Lễ Mình Thánh và Máu Thánh Chúa Giêsu                           |
| Holy Mary the Mother of God             | Đức Mẹ là Mẹ Thiên Chúa (1-1)                                   |
| Her Immaculate Conception               | Lễ Đức Mẹ Vô nhiễm  |
| Her Assumption                          | Đức Mẹ Hồn Xác Lên Trời   |
| Saint Joseph                            | Kính Thánh Cả Giuse (3/19)                                      |
| Saint Peter and Saint Paul the Apostles | Kính Thánh Phêrô (6/29)<br>Sinh Nhật Thánh Gioan Tẩy Giả (6-24) |
| All Saints                              | Lễ Các Thánh (11-1)   |

## Prayer

*Dear God, please help me to love you and obey your rules!*

## Practicing our Faith

Whenever we go to Mass, the Lord speaks to us through his Holy Word; we are united with Jesus in the Sacrifice he offered on the Cross for our salvation; we meet him in Holy Communion; we receive the power of his Holy Spirit; and we are united with the whole Church across time and space. It is the holiest act of worship possible on earth. Sometimes we feel inspired, sometimes we feel a bit dry; sometimes we feel very peaceful, sometimes we are completely distracted.

The important thing is that we are there, every Sunday. This is not so much a duty, as an invitation. The Lord is there for us. He asks us to love and honour him, and invites us to share his life. How can we refuse? Whatever is happening in your life, however difficult or dry things are – do everything you can to be at Sunday Mass. Don't pretend it doesn't matter, or you are too busy.

## Faith Alive at Home

### Discussion

What is the difference between honoring and fearing God?

### True or False

Holy Days of Obligations are the same as Holy days of Memorial. T/F

Holy days of Memorial have 3 readings. T/F



# Vestment and Colors of the Liturgical Year

## Reading the Bible

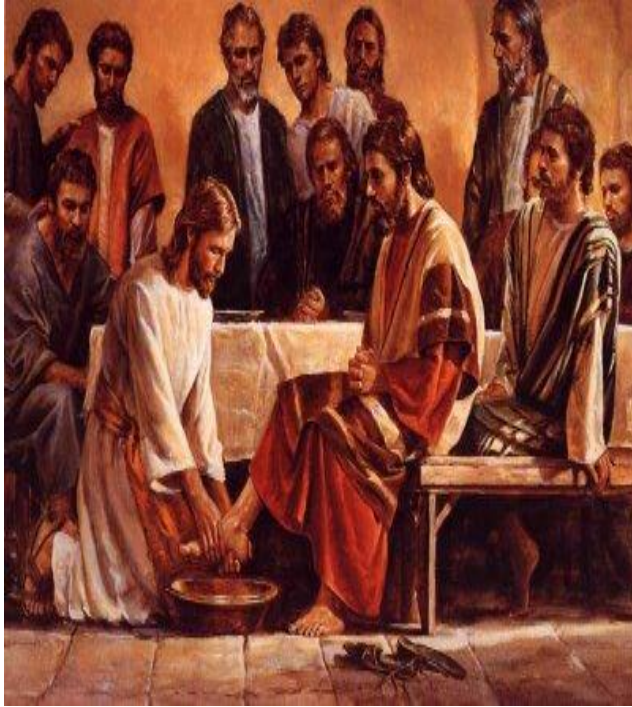

em."(Ga 13, 1,4-5, 12-15)

<sup>1</sup> Before the feast of Passover, Jesus knew that his hour had come to pass from this world to the Father. He loved his own in the world and he loved them to the end. ... <sup>4</sup> he rose from supper and took off his outer garments. He took a towel and tied it around his waist. <sup>5</sup> Then he poured water into a basin and began to wash the disciples' feet and dry them with the towel around his waist. .... <sup>12</sup> So when he had washed their feet (and) put his garments back on and reclined at table again, he said to them, "Do you realize what I have done for you?" <sup>13</sup> You call me 'teacher' and 'master,' and rightly so, for indeed I am. <sup>14</sup> If I, therefore, the master and teacher, have washed your feet, you ought to wash one another's feet. <sup>15</sup> I have given you a model to follow, so that as I have done for you, you should also do (John 13, 1,4-5, 12-15)

## Studying Our Faith

1. "What do you call that thing that the priest is wearing?" This is a commonly asked question that Catholics ask because they do not know what to call the clothing that is being worn by the clergy.
2. The word "vestment" comes from the Latin. It simply means clothing. Now, it is generally used to represent the garments that are worn by the ministers of religion in the performance of their sacred duties.

3. Vestments are a sacramental. That means they are set apart and blessed by the Church to excite good thoughts and to increase devotion in those who see and those who use them. They are the uniform of the priest when he is "on duty," while he is exercising the functions of his ministry and using the sacred powers which he received at his ordination. The clothing that is worn by the priest while he is not "on duty," it is not called vestments.

4. The Mass vestments were originally ordinary garments of the ancient Roman world. While the fashions of dressing have changed with the passing centuries, the priest continued to wear at the altar the ancient Roman costume of his predecessors.

5. Thus, the priest, vested for mass, is a wonderful witness to the historical continuity of the Catholic Church with the primitive Church of Rome, founded by the Prince of the Apostles.



a) Khăn Lễ (*Amice*) – khăn lễ trùm đầu hoặc vai khi cử hành Thánh Lễ mang ý nghĩa việc tránh xa mọi cám dỗ (*a white cloth around the shoulders to signify resistance to temptation*)



b) Áo Dài Trắng (*Alb*) – áo dài trắng mang ý nghĩa trong sạch và thánh thiện (*a long white garment to signify innocence*)

c) Dây thắt lưng (*Cincture*) – dây thắt lưng tượng trưng cho sự giản dị (*a cord about the waist to signify chastity*)





d) Khăn Su Tang (*Stole*) – khăn quàng trên cổ đại diện cho sự sống bất diệt (*a long vestment about the neck to signify immortality*)



e) Áo Lễ (*Chasuble*) – Áo Lễ tượng trưng cho tình yêu và nhắc nhở Linh Mục với Thánh Giá đằng trước và sau áo Lễ lòng mến Thiên Chúa (*long vestment over all, to signify love and remind the priest, by its cross on front and back, of the Passion of Our Lord*)

2) Các Màu Sắc của Phẩm Phục của các Linh Mục trong Thánh Lễ (the colors of the vestments of the Priests at Mass)

**a) Màu Trắng (white):** Chỉ sự trong sạch, thánh thiện, chiến thắng, vui mừng  
Mùa giáng sinh - Phục sinh - Lễ về Chúa (trừ Chúa Nhật lễ lá và thứ 6 tuần thánh) - Lễ về Đức Mẹ, thiên thần, các thánh nam nữ, các thánh không tử đạo - Lễ thánh Gioan Tẩy Giả - Lễ thánh Gioan tông đồ - Lễ kính tòa thánh Phêrô - Lễ thánh Phaolô trở lại.

*White signifies innocence and is used on the feasts of Our Blessed Lord, of the Blessed Virgin, and of some saints.*

**b) Màu Đỏ (red):** Chỉ sự hiến dâng cuộc sống cho Chúa; máu, lửa, hy sinh và chiến thắng tử đạo. Chúa Nhật lễ lá - Thứ 6 tuần thánh (cuộc khổ nạn của Chúa) - Lễ hiện xuống - Các thánh tông đồ và các thánh tử đạo (trừ thánh Gioan tông đồ) - Các thánh tử đạo

*Red signifies love, and is used on the feasts of the Holy Ghost, and of martyrs*

**c) Xanh lá cây (Green):** Chỉ sự hy vọng, sức chịu đựng bền bỉ trong đức tin  
Mùa thường niên

*Green signifies hope, and is generally used on Sundays from Epiphany to Pentecost.*

**d) Tím (violet):** Chỉ sự thống hối, ăn năn nói lên sự hoán cải. Mùa vọng - Mùa chay - Lễ cầu hồn (ở Hoa Kỳ thay bằng màu trắng)

*Violet signifies penance, and is used in Lent and Advent.*

**e) Hồng (pink):** Chỉ niềm vui trước kỳ hạn thống hối. Chúa Nhật thứ 3 mùa vọng - Chúa nhật thứ 4 mùa chay

**f) Vàng (yellow):** Tăng phần long trọng

*Gold is often used for white on great feasts.*

**g) Đen (black):** Chỉ sự tang chế, cầu hồn, an táng (Old tradition. Được thay bằng màu Trắng)

*Black signifies sorrow, and is used on Good Friday and at Masses for the dead.*

## Summary

1. Các Phẩm Phục của Linh Mục trong Thánh Lễ gồm có: Khăn trùm vai, áo dài trắng, dây thắt lưng, khăn su tang và áo lễ. *ce, Alb, Cincture, Stole and Chasuble)*

2) Các Màu Sắc của Phẩm Phục gồm có: Trắng, Đỏ, Xanh lá cây, Tím, Hồng, Vàng và Đen và mỗi màu có ý nghĩa riêng *(the colors of the vestments include: white, red, green, violet, pink, yellow and black and each color carry different meaning)*

## Prayer

Lạy Chúa qua bài học này con biết được rằng, những màu sắc mà Thiên Chúa đã dựng nên cho chúng con trên trái đất này, đều mang những ý nghĩa cho loài người chúng con. Xin ban cho chúng con ơn hiểu biết hơn nữa, để chúng con cảm nhận và cùng hiệp thông với những màu áo những Thánh lễ mà lâu nay chúng con chỉ biết nhìn nhưng không thấu hiểu những điều mà Thiên Chúa muốn nhắc nhở chúng con qua các màu áo Lễ.

Amen.

## Practicing Our Faith & Faith Alive at Home

During today's mass, notice the color of the priest's vestments and any cloth items that might decorate the front of the altar or cover the tabernacle. At home, discuss with your parents how colors symbolize the church's five liturgical seasons of Advent, Christmas, Lent, Easter and Ordinary Time. Create a map or wheel to track the liturgical seasons and share with class next week.

[http://www.ehow.com/list\\_6621342\\_children\\_s-activities-learn-catholic-mass.html#ixzz1YwFG93hV](http://www.ehow.com/list_6621342_children_s-activities-learn-catholic-mass.html#ixzz1YwFG93hV)

# The Altar and Objects Needed For Mass

## Reading the Bible

**Luke 22: 7, 19, 20** <sup>7</sup> “Then came the day of Unleavened Bread on which the Passover lamb had to be sacrificed.” <sup>19</sup> “And he took bread, gave thanks and broke it, and gave it to them, saying, “This is my body given for you; do this in remembrance of me.” <sup>20</sup> “In the same way, after the supper he took the cup, saying, “This cup is the new covenant in my blood, which is poured out for you.

## Studying our Faith



### The things needed for Mass are:

- **ALTAR** - The central object of the Church. The table on which the offerings [the sacrifice] of the Mass are consecrated. An Altar with linen covers, candles, crucifix, altar stone, and Mass book
- **ALB**: the white robe that the priest and servers wear.
- **CINCTURE**: rope “belt” that is tied around the alb.
- **STOLE**: the thin “scarf-like” part of the priest’s vestment.

- **CHASUBLE:** the large colored garment worn by the priest over his alb. [the different colors are for the different “Seasons” of the Church’s year]
- **CORPORAL:** the square “place mat” placed on the Altar by the priest when preparing the gifts.
- **CHALICE:** a cup used for the distribution of the consecrated wine [“the Blood of Christ”].
- **CIBORIUM:** a plate or bowl used for the distribution of the communion bread [“the Body of Christ”].
- **PURIFICATOR:** a small white cloth used to wipe off the communion cups.
- **CRUETS:** small containers used for water and wine.
- **CARAFE** - Larger “pitchers” used to hold the water and wine.
- **SACRAMENTARY:** the big, red book used by the priest for the various prayers.
- **LECTIONARY:** the large book carried by the Lector used for the Scripture readings. This book is always on the pulpit/ambo.
- **PROCESSIONAL CROSS:** a cross or crucifix carried by the server in the procession in and out.
- **THURIBLE:** used for incense [looks like a decorated bowl on a long chain].

<http://www.mtcarmel-ash.org/parish/AlterServerGuidelines.PDF>

## Summary

God created the world to exist in a rhythm, and rhythm created for us, His beloved creation, so that we are able to live and thrive harmoniously. As Catholics, experiencing and participating in Mass at least every Sunday is essential to keep our rhythm in tune with God. Understanding the Mass and all the things used during Mass helps us to fully appreciate our special time with Jesus.

## Prayer



*Dear God, thank you for the knowledge of the mass that I learned in this lesson. I want to pay more attention and attend mass wholeheartedly from now on. Please help me!*

## Living Our Faith

Our chaplain will take us through the church, he will show us the things that used during mass and briefly explain how and why they're used. We will also visit the sacristy to see the vestments the priest wears during Mass.

## Practicing Our Faith

Take notes during the visit and work together with the team to draw on the posters everything that you learned today. Prepare to share with the class next week.



# Before and After Meals Prayers

## Fact Finding

Christians frequently pray before meals, giving thanks to God for the food we are about to eat. Pre-meal prayers can be a simple “thank-you” to God for the meal or lengthier prayers of thanksgiving for all of His provisions in our lives. In praying before meals, we are following the example of the Lord Jesus, whose prayers on several occasions are our model.

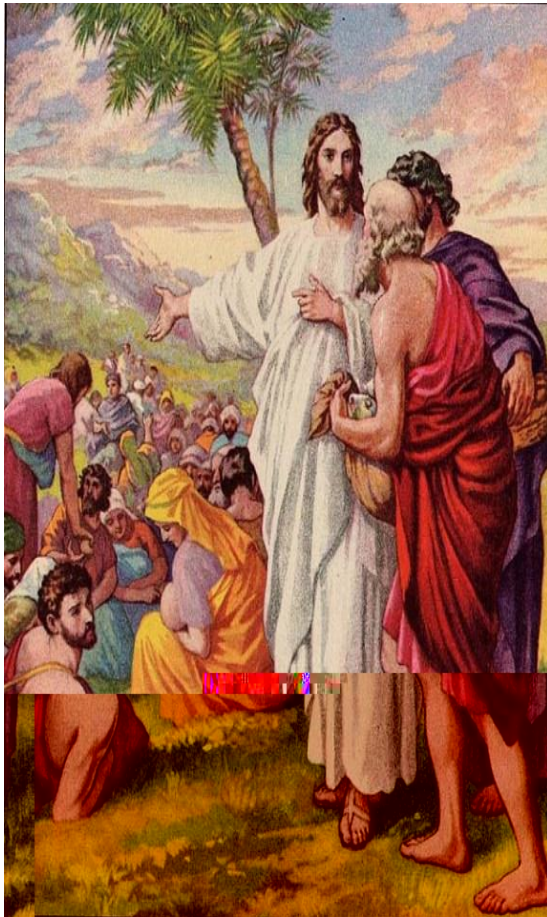

In the two instances where Jesus miraculously fed multitudes of people with a few loaves and fish, He “gave thanks” ([Matthew 14:19-21](#); [15:34-36](#)). In the first instance, He fed 5000 men, plus women and children, with five loaves of bread and two fish. In the second, He fed over 4000 with seven loaves and a few fish. At the Last Supper, Jesus again set the example of thanksgiving. When He passed the cup and the bread to His disciples, telling them to eat and drink these elements which were symbols of His body and blood, He gave thanks. When He appeared to the two men on the road to Emmaus after His resurrection, He stopped briefly to eat with them, and “took bread, gave thanks, broke it and began to give it to them” ([Luke 24:30](#)).

The apostle Paul continued this example of praying before eating, as recorded in Acts 27. In this instance, Paul was on a ship with 276 other people when a hurricane battered the ship.

After fourteen days of not eating, Paul exhorted the sailors and other passengers to eat something in order to survive. He “took some bread and gave thanks to God in front of them all” ([Acts 27:35](#)). Even in spite of the danger and terrible circumstances, Paul paused to give thanks to God before the meal.

## Kinh Trước Bữa Ăn

Nguyện xin, nguyện xin Chúa cả mở  
tay chúc phúc. Cho chúng con dùng, cho chúng  
con dùng nên các thực phẩm này

## Kinh Sau Bữa Ăn

Đội ơn Chúa đời đời mạch sống.  
Đã nuôi chúng con hồn xác hôm nay.  
Nguyện danh Chúa đời đời cả sáng.  
Xướng cho mọi loài ơn lộc no đầy.

## Summary

When we thank God for providing our daily bread, we are acknowledging that all things come from Him ([Ephesians 5:20](#); [Romans 11:36](#)). He is the source of everything we have, and praying before meals as a habit helps to remind us of that truth. Praying before we eat with a thankful heart brings glory to God and centers our minds on His great love for His children and the blessings He bestows on those who belong to Him.

## Homework



Learn the prayers and share the prayers with your family before and after meal this week.

# Living the Eucharistic Day

## Fact Finding

**Matthew 26:26-29** <sup>26</sup> While they were eating, Jesus took bread, and when he had given thanks, he broke it and gave it to his disciples, saying, “Take and eat; this is my body.”

<sup>27</sup> Then he took a cup, and when he had given thanks, he gave it to them, saying, “Drink from it, all of you. <sup>28</sup> This is my blood of the <sup>[a]</sup> covenant, which is poured out for many for the forgiveness of sins. <sup>29</sup> I tell you, I will not drink from this fruit of the vine from now on until that day when I drink it new with you in my Father’s kingdom.”

## SPIRITUALITY OF EUCHARISTIC YOUTH SOCIETY

**Spirituality is the spiritual method that religious orders and societies choose to follow in life.**

**St. Vincent de Paul society’s spirituality is charity works.**

**Linh thao’s spirituality is words of God in the Bible.**

**Eucharistic You s et s pi t t s th ly**

A spiritual food: **To nourish the soul.**

A method: **Power to eliminate faults and avoid sins.**

A guarantee: **For the life to come: eternal reward. (John 6: 50 – 51)**

An Union: **Unite us closely with God. Maintain and improve the union, the relation between God and the church and us. Manifest the relationship of all parts of the Body of Christ. (*Union of Bread and Wine. John 6: 56 – 57*)**

The true presence of God: **Jesus with His nature of God and of Man.**

**1<sup>st</sup> miracle: God is truly present in the Holy Eucharist.**

**2<sup>nd</sup> miracle: the indifference of Christians toward the Holy Eucharist.**

A new covenant: **Covenant of love.**

A thanksgiving: **Of Jesus to God the Father for mankind.**

## Activity

### Living the Eucharistic Day

#### 1. Starting with morning prayers

- a. The Eucharistic Day is a day lived by youth with Jesus as the sun, the center of life. The Eucharistic Day is started with the morning prayers.
- b. The sun starts to rise, opening a new horizon with hope through the guidance of God.
- c. Morning offering and consecrate our day's activities to Almighty God and offer Him all our prayers, works, joys and sufferings, through the intercession of the Immaculate Heart of Mary, the Mother of God

#### 2. Received God into our heart (the Mass & the Holy Communion)

- a. The peak of Eucharistic Day is the Mass and Holy Communion. The time of Eucharistic Day is marked with prayers, spiritual communion, sacrifices, rosary, and apostolate works...
- b. The sun at noon, staggered with daily works (prayers, spiritual communion, sacrifices, rosary, apostolate works...)
- c. Christians, especially Thiều Nhi must recognize the Mass and the Holy Communion as center of life.

#### 3. Ending the day with night prayers

- a. The Eucharistic Day ends with spiritual flower bouquet and the offering of the night.

- b. Spiritual flower bouquet is a spirituality of reflecting our own life. Spiritual flower bouquet, conscience examination, act of contrition, offering good works to God, also weakness to ask God for pardon and help...
- c. When the night comes, covering darkness provokes a sense of fear in us. When the sun sets, let Jesus in the Holy Eucharist set in our heart so we can have peace.

## Summary

Living the Eucharistic Day is living in the graces of God.

The Eucharistic Day is a method to help us become a saint. Living the Eucharistic Day is a fundamental and special method of the Eucharistic Youth Society, a method that help us to progress to sainthood through the practice of spiritual flower bouquet.

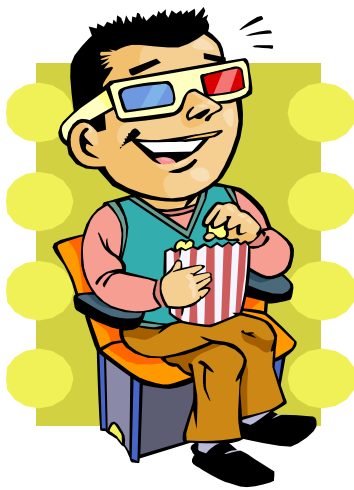

## 3D Method

**Dâng Ngày**

**3D = Dụ Lễ**

**Dâng Đêm**

## Homework

This week, our ngành Thiếu will kick-off 1 week of Spiritual Bouquet Campaign with the theme, “Living An Eucharistic Day”. As a team:

1. Design a spiritual bouquet for each member to track Living An Eucharistic Day activities
2. Gather the results and create a Spiritual Bouquet for your team
3. Prepare to offer the bouquet during Mass next week



# MORSE CODE

## Introduction to Morse

Morse is form of communication using sounds to transmit textual information.



## Situation

When do you use Morse code in TNTT?

- To call kids into line formations
- To relay a message

Why does TNTT use Morse code in these situations?

1. Line formations: We use Morse code to call the kids into line formations. We use the abbreviations of each nganh to differentiate between the nganhs that we are calling into formation.
2. Relaying messages: At Thieu Nhi we can relay coded messages written in Morse code. This can be used to start “The Journey of Faith” activities. They can also be used written down so that others can decode a secret message.

## Morse Pyramid

We can use the Morse Pyramid to help us learn the Morse Letters.

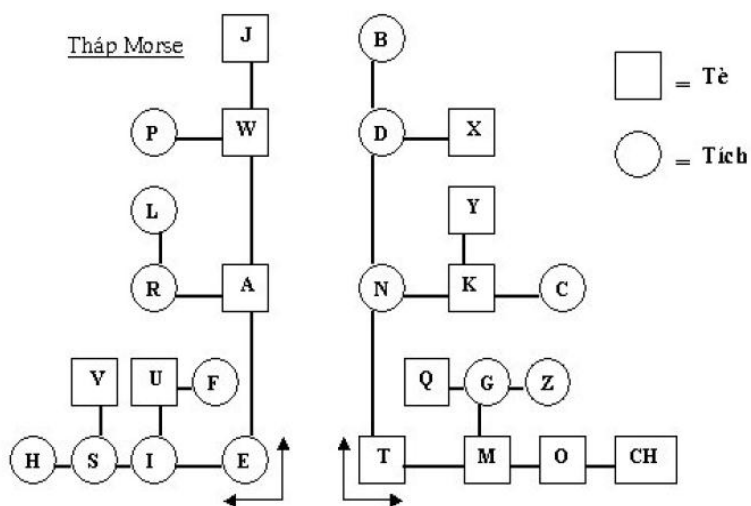

## Summary

1. Morse is used to send messages.
2. Morse is used to assemble TNTT.

## Prayer



Dear Jesus, help me learn new things with my friends everyday.

# MORSE CODE A-Z, 0-9

## Morse Code Alphabet and Numbers

|        |        |        |         |
|--------|--------|--------|---------|
| A ··   | J ···· | S ...  | 1 ····· |
| B ···· | K ···  | T =    | 2 ····· |
| C ···· | L ···· | U ...  | 3 ····· |
| D ...  | M =    | V ···· | 4 ····· |
| E ·    | N ··   | W =·   | 5 ····· |
| F ···· | O =·   | X ···· | 6 ····· |
| G =·   | P ···· | Y =··· | 7 ····· |
| H ···· | Q =··· | Z =··· | 8 ····· |
| I ··   | R ...  |        | 9 ····· |
|        |        |        | 0 ····· |

## Learning Strategy

Review the sound represented in Morse code. The short sound (tích) stands for the dot. The longer (tè) stands for the dash. Practice listening to the different letters that are blown and record them down on paper.

## Prayer



Dear Jesus, help me learn to work with my team and remember Morse.

# Tua Khen Thưởng

## Basic knowledges



### Chương IV Nghiệm Tập : Nghi Thức Lãnh Thưởng

#### I. Tổng Quát Về Khen Thưởng

Trong các sinh hoạt của Thiếu Nhi Thánh Thể, khen thưởng là một cách giáo dục không những nên cao tinh thần đồng đội, mà còn làm phát triển khả năng của cá nhân. Vì thế, lễ nghi khen thưởng cũng mang các hình thức: Khen Thưởng Cá Nhân, Khen Thưởng Đội, Khen Thưởng Nhiều Đội ... Phong Trào Thiếu Nhi Thánh Thể dùng tua, cờ danh dự, bằng khen, kỷ vật, v.v... để khen thưởng.

#### II. Ý Nghĩa Màu Tua

Thiếu Nhi Thánh Thể dùng màu sắc của các Ngành để làm màu tua khen thưởng, và mỗi màu tua đều mang một ý nghĩa rõ rệt:

#### A. **Tua Màu Xanh Lá Cây:** (Phụng Vụ) – Spiritual

Màu xanh lá cây là màu của Ngành Áu, tượng trưng tinh thần cầu nguyện. Tua màu xanh lá cây dùng để khen thưởng những việc lành đạo đức, những sinh hoạt lễ nghi phụng vụ đặc sắc, hoặc những công việc làm triển nở đức tin và lòng sung đạo.

#### B. **Tua Màu Xanh Biển:** (Sinh Hoạt) – (Activities, Songs, Movements, Be Prompt, Skits)

Màu xanh nước biển là màu của Ngành Thiếu, tượng trưng tinh thần hy sinh, luôn sống vui trong gian khổ, cũng như mang niềm vui đến cho mọi người. Tua màu xanh biển dùng để khen thưởng những sinh hoạt ca vũ vui tươi, những mục văn nghệ đặc sắc, những tài năng sáng tác, nhất là những sang kiến gây tạo bầu khí vui nhộn thoải mái trong sinh hoạt.

#### C. **Tua Màu Vàng:** (Học Tập) - Learning

Màu vàng là màu của Ngành Nghĩa, tượng trưng tinh thần đi gieo, luôn cố gắng trau dồi khả năng để ngày nay học tập, ngày mai giúp đời. Tua màu vàng dùng để khen thưởng những sinh hoạt học tập, báo thí, những nghệ thuật đặc sắc, độc đáo và phong phú; những kỹ thuật chuyên môn trong sa mạc như: thủ công lều trại, hoặc sáng chế những vật dụng hữu ích cho đời sống.

#### D. **Tua Màu Đỏ:** (Tinh Thần) – Highest Honor, Spirit

Màu đỏ của Trưởng, tượng trưng tinh thần phụng sự cao độ, xả thân cho lý tưởng. Tua đỏ dùng để khen thưởng tinh thần toàn diện gồm cả tự nhiên lẫn siêu nhiên. Tinh thần nhịn nhục, vị tha, tận tụy trong mọi công việc, tinh thần kiên nhẫn trong mọi thử thách, tinh thần phục thiện trong mọi lỗi lầm, tinh thần hòa nhã trong mọi việc tiếp giao...

# Accepting Awards by Individual and By Teams

## Basic Knowledge

### V. Diễn Tiến Lãnh Thưởng (Nghiêm Tập Phong Trào Chương V

#### A. Khen Thưởng Cá Nhân: Individual

1. Khi nghe gọi tên, cá nhân mau mắn chỉnh tề lại y phục, chạy thẳng lên đứng thế nghiêm trước mặt vị chủ tọa và hàng quan khách cách ba bước, giơ tay chào hàng Trưởng và Quan Khách ( ).
2. Người được mời phát thưởng tiến đến trước mặt người được lãnh thưởng, phát thưởng hoặc gắn tua ( ).
3. Người phát thưởng bắt tay chúc mừng ( ).
4. Chờ người phát thưởng về chỗ rồi, cá nhân chào hàng Trưởng và Quan Khách.
5. Sau đó cá nhân tự động quay trở về chỗ của mình ( ).



6. Trưởng Trục bắt bài hát khen thưởng.

#### B. Khen Thưởng Nhiều Cá Nhân:

1. Khi nghe gọi tên, lần lượt từng cá nhân mau mắn chỉnh tề lại y phục, chạy lên đứng dàn hàng ngang nghiêm chỉnh trước mặt hàng Trưởng và Quan Khách cách ba bước. Người đứng đầu hàng phía trái hàng Trưởng và Quan Khách hô: “**Chuẩn bị chào ... Chào!**”. Chào hàng Trưởng và Quan Khách.
2. Vị chủ tọa có thể mời nhiều người ra phát thưởng hoặc trao tua cùng một lúc.
3. Phát thưởng xong, người phát thưởng bắt tay chúc

mừng ( ).

4. Chờ người phát thưởng về chỗ rồi, người đứng đầu hàng phía trái Trưởng và Quan Khách hô: “**Chuẩn bị chào ... Chào!**”. Chào hàng Trưởng và Quan Khách.

5. Sau đó, các cá nhân tự động di chuyển về vị trí đội của mình ( *khác*).

6. Trưởng Trục bắt bài hát khen thưởng.

### **C. Khen Thưởng Đội:**

1. Được lệnh lên lãnh thưởng, Đội Trưởng báo cho đội viên chỉnh tề y phục.

2. Đội Trưởng hô tên đội một lần: “**Seraphim**”, cả Đội đáp lại khẩu hiệu đội: “**Trong trắng!**”. Sau đó dùng cờ lệnh cho Đội quay bên phải, rồi dùng khẩu lệnh hô: “**Đàng trước ... Bước!**”.

3. Đội Trưởng dẫn Đội chạy vòng ra bên ngoài đội hình ngược chiều kim đồng hồ, đến sắp thành hàng ngang trước mặt hàng Trưởng và Quan Khách cách bốn bước, lấy vị trí của vị chủ tọa làm chuẩn đứng giữa.

4. Đội Trưởng so hàng đội, sau khi hô tên đội và cả Đội đáp lại khẩu hiệu đội, Đội Trưởng dùng cờ lệnh lần khẩu lệnh cho Đội quay mặt vào hàng Trưởng và Quan Khách: “**Bên trái ... Quay!**”, “**Chuẩn bị chào ... Chào!**”. Chờ hàng Trưởng và Quan Khách chào lại xong, rồi tất cả bỏ tay xuống.

5. Đội Trưởng tự động tiến lên trước mặt vị chủ tọa cách ba bước (*không chào*). Tay phải đưa thẳng cờ lên, rồi hạ nằm ngang vai về phía trước, hợp với thân mình một góc 90 độ, tay trái chuôi cán cờ sát nách, lòng bàn tay úp xuống đất.

6. Chờ người phát thưởng gắn tua trên cờ xong, thì đưa thẳng cờ lên rồi hạ xuống và chuyển cờ ngay sang tay trái để bắt tay người phát thưởng. ( *hen* ). Sau khi phát thưởng xong, Đội Trưởng tự động trở về vị trí đội.

7. Đội Trưởng ra lệnh cho Đội chào hàng Trưởng và Quan Khách: “Chuẩn bị chào ... Chào!”. Sau đó di chuyển Đội về vị trí bằng khẩu lệnh: “**Bên phải ... Quay!**”, “**Đàng trước ... Bước!**” (Nhớ chạy vòng sau lưng hàng Trưởng và Quan Khách ngược chiều kim đồng hồ).

8. Trưởng Trục bắt bài hát khen thưởng.

9. Về tới vị trí đội, Đội Trưởng dùng cờ lệnh so hàng và cho Đội quay về vị Trí đội hình.

#### D. Khen Thưởng Nhiều Đội:



1. Được lệnh lên lãnh tua/bằng khen, Đội Trưởng báo cho đội viên chỉnh tề y phục.

2. Đội Trưởng hô tên đội một lần: “**Seraphim**”, cả Đội đáp lại khẩu hiệu đội: “Trong trắng!”. Sau đó dùng cờ lệnh cho Đội quay phải, rồi dùng khẩu lệnh hô: “Đàng trước ... Bước!”.

3. Các Đội Trưởng lần lượt dẫn Đội chạy vòng ra bên ngoài đội hình ngược chiều kim đồng hồ, đến sắp thành nhiều hàng Trưởng và Quan

Khách, Đội đứng trước cách bốn bước, lấy vị trí của vị chủ tọa làm chuẩn đứng giữa.

4. Đội Trưởng so hàng đội, sau khi hô tên đội và cả Đội đáp lại khẩu hiệu đội, Đội Trưởng dùng cờ lệnh lần khẩu lệnh cho Đội quay mặt vào hàng Trưởng: “**Bên trái ... Quay!**”, và đứng nghiêm đôi lệnh.

5. Khi các Đội đã đầy đủ và nghiêm chỉnh trong hàng ngũ, Đội Trưởng Đội đứng hàng đầu ra lệnh cho các Đội chào hàng Trưởng và Quan Khách: “**Chuẩn bị chào ... Chào!**”. Chờ hàng Trưởng và Quan Khách chào lại xong, rồi tất cả bỏ tay xuống.

6. Các Đội Trưởng tự động tiến lên đứng dàn hàng ngang trước mặt vị chủ tọa cách ba bước (không chào).

7. Vị chủ tọa thể mời nhiều người ra gần tua và trao bằng khen thưởng cùng một lúc.

8. Các Đội Trưởng tay phải đưa thẳng cờ lên rồi hạ nằm ngang vai về phía trước, hợp với thân mình một góc 90 độ, tay trái cầm chuỗi cán sờ sát nách, lòng bàn tay úp xuống đất.

9. Chờ người phát thưởng gắn tua trên cờ xong, thì đưa thẳng cờ lên rồi hạ xuống và chuyển cờ ngay sang tay trái để bắt tay người phát thưởng.

. Sau khi phát thưởng xong, các Đội Trưởng tự động trở về vị trí đội ( ).

10. Đội Trưởng đứng hàng đầu ra lệnh cho các Đội: “**Chuẩn bị chào ... Chào!**”. Chờ hàng Trưởng và Quan Khách chào lại xong, rồi tất cả bỏ tay xuống. Sau đó, di chuyển Đội về vị trí bằng khẩu lệnh: “**Bên phải ...**

**Quay!**”, “**Đàng trước ... Bước!**”. Đội đứng hàng đầu chạy trước, các Đội khác lần lượt chạy tiếp theo sau vòng ra bên ngoài đội hình ngược chiều kim đồng hồ để về vị trí đội.

11. Trưởng Trục bắt bài hát khen thưởng.

12. Về tới vị trí đội, Đội Trưởng dùng cờ lệnh so hàng và cho Đội quay về vị trí đội hình.



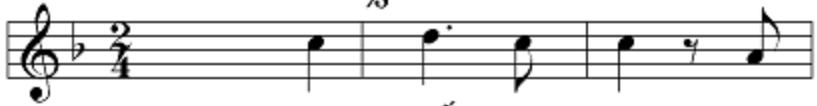

# SEARCH DIVISION OFFICIAL SONG

## Song: Thiếu Nhi Ca

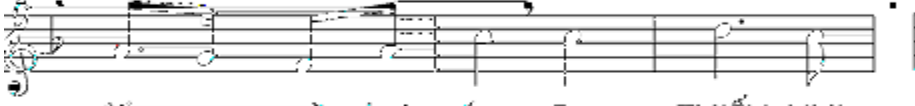

  
 1. Em THIẾU NHI ơi, như  
 2. Em THIẾU NHI ơi, mắt

  
 ngàn tia sáng huy hoàng, vào buổi rạng đông

  
 đến mang nguồn hơi ấm. Em THIẾU NHI  
 xóa tan màu u tối. Em THIẾU NHI

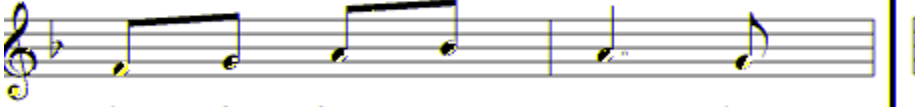
  
 ơi, em đẹp như hoa hướng dương, tươi  
 ơi, em là chiến sĩ phúc âm, gian

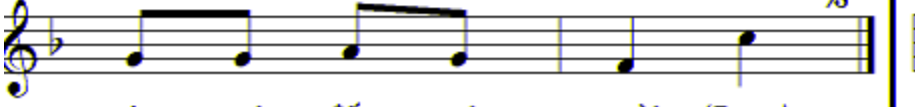
  
 dịu như hơi gió xuân đem  
 khổ nguy khó chớ nao vui

  
 yên vui đến muôn người. (Em...)  
 mang Chúa đến cho người.

### Meaning of Song

The Search Division Youths are like a thousand rays of sunlight bringing warmth in the dawn.

You are beautiful as a sunflower; fresh like the spring air bringing happiness to everyone.

Your eyes are stellar; the smile on your lips takes away the darkness.

You are a fighter for the Gospels, not scared of obstacles and hardships, happily bringing God to everyone.



# Thiếu Nhi Tân Hành Ca

Song

[http://tnnt.lavangnm.org/\\_nhac/\\_midi/\\_chinhthuc/thieunhitanhanhca.mid](http://tnnt.lavangnm.org/_nhac/_midi/_chinhthuc/thieunhitanhanhca.mid)

## Thiếu Nhi Tân Hành Ca

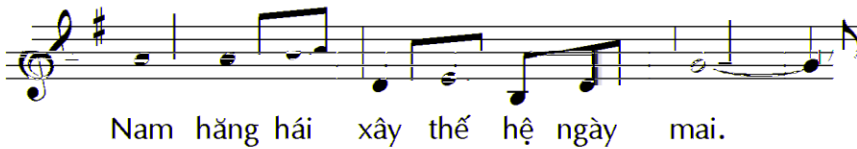
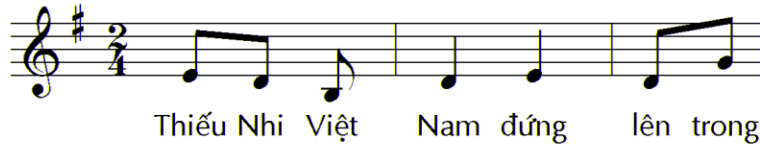

ý tưởng của người Thiếu Nhi hôm nay.



# Đi Theo Cột Mây

## Song

<http://tntt.lavangnm.org/nhac/pdf/thieunhi/ditheocotmay.pdf>

<http://tntt.lavangnm.org/nhac/midi/thieunhi/ditheocotmay.mid>

Vàng mây che ban ngày khi nắng vàng soi trần gian  
Và có ánh Đuốc Thiêng lúc nắng hồng đã lịm tắt  
Ta đi theo lời hứa, tiến bước trong niềm tin

## Meaning of Song

Because Jesus loves us, He is always beside us wherever we go. Jesus is our friend, so we should be happy and play together in His presence (“We turn, and we clap, and we shout ‘Jesus Christ!’”)

**NOTE: ALL INFORMATION ON THIS DOCUMENT WAS RETRIEVED FROM VARIOUS SITES ON THE WORLD WIDE WEB. THIS DOCUMENT IS NOT INTENDED FOR COMMERCIAL SALES OR DISTRIBUTION FOR PERSONAL FINANCIAL BENEFITS.**